



## **Installation Instructions**

**Step 1 – Taking Delivery and Checking All Parts**

**Step 2 – Preparing the Motor and Barrel**

**Step 3 – Preparing the Guide Rails**

**Step 4 – Fixing the Guide Rails and Box Assembly**

**Step 5 – Fitting the Remote-Control Unit**

**Step 6 – Installing the Curtain**

**Step 7 – Setting the Motor Limits**

**Step 8 – Fitting the Front Box/enclosure (optional)**

**Step 9 – Installing the emergency override**

# **IMPORTANT SAFETY INSTRUCTIONS**

**ADHERE TO THE INFORMATION PROVIDED TO ENSURE THE PRODUCT IS INSTALLED AND OPERATED IN THE CORRECT MANNER TO PREVENT DAMAGE OR INJURY.**

- **At least TWO experienced and qualified roller shutter door engineers are required to install this product.**
- **When the product is unpackaged ensure care is taken to avoid any damage.**
- **Wear suitable clothing, head/hand protection and take all necessary safety precautions when drilling or working from height to avoid injury.**
- **Make sure no sharp objects come into contact with the product to avoid damage.**
- **Ensure the site is clear of any obstacles prior to installation.**
- **Refer to MANUFACTURERS instructions when installing the control unit and external override.**
- **The control unit comes with a 3-pin plug (13-amp fuse) to be plugged in directly to a standard 13-amp socket. If any alterations are necessary, please ensure a qualified electrician undertakes the work.**
- **Your control unit must be installed in a dry location that is at a height for you to easily operate the garage door. Ensure this is out of reach of children to avoid misuse and potential injury. Also, keep the remotes out of reach.**
- **Always operate your door when in full view to avoid any accidents or injury.**

**Please note the instructions are for guidance only. Each installation is different so you must assess your own site prior to installing.**

## Step 1 – Taking Delivery and Checking All Parts

Please check that the door is the correct size, all component parts are present and the condition. Any damage must be reported This garage door is heavy and awkward to handle, installation of the door must be carried out by two qualified engineers.

Figure 1

You should have:

- 1) Box containing door curtain
- 2) Two guide rails
- 3) Box containing electronic controls
- 4) Manual override equipment
- 5) Motor barrel containing the motor



Ensure that the site is clear and that the fixing surfaces are free from loose plaster and masonry. Ensure that the opening has no irregularities that could damage the back box or curtain.

The door curtain will be fully packaged when delivered. The end plates will be factory fitted to the back box (if ordered) and the curtain will be packaged with bubble wrap. The two side channels (guide rails) should be unpacked and placed into either side of the opening. The guides are designed to slot into the end plates via the peg on the end plate. PLEASE ENSURE NO EXCESSIVE FORCE IS PLACED ONTO THIS PART AS IT IS ONLY DESIGNED AS A GUIDE TO SET OUT WHERE THE RAILS NEED TO GO. PLEASE ALSO ENSURE YOU HAVE AT LEAST 10MM TOLERANCE FROM THE CEILING AS YOU WILL NOT BE ABLE TO OFFER THE FRAME UP OTHERWISE AS IT WILL BE TOO TIGHT TO THE CEILING. IF YOU TRY AND FORCE IT INTO PLACE, THE PEG WILL BREAK. THE GUIDES CAN BE CUT DOWN TO REDUCE THE HEIGHT OF THE DOOR.

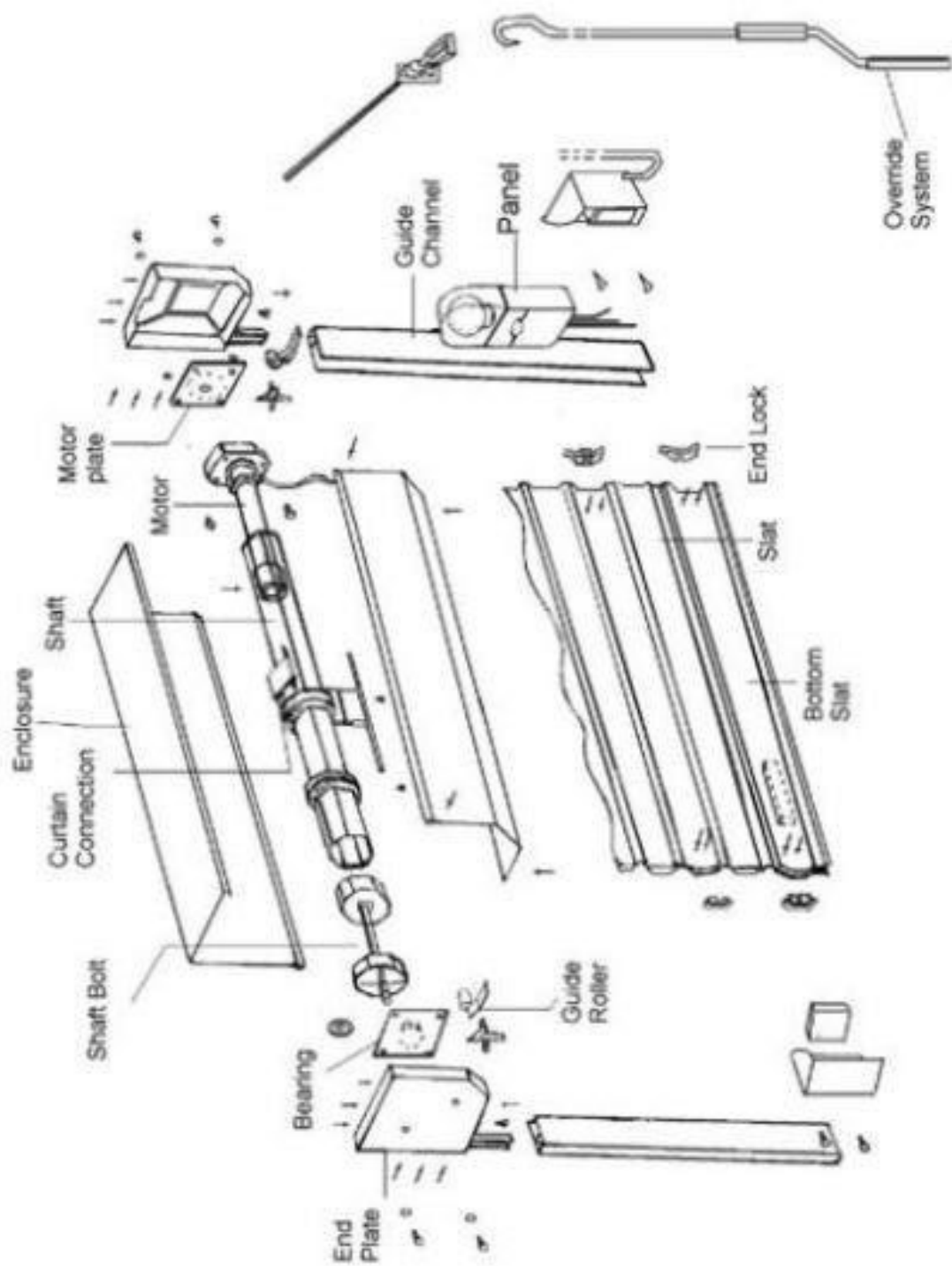

## Step 2 – Preparing The Motor And Barrel

1. Carefully remove the box lid and place in a safe place – IF APPLICABLE.

The barrel (shaft) is held in place by a captive bearing (or safety brake if applicable) on the non-drive end and a mounting plate on the drive end. The non-drive end of the barrel has an adjustable shaft (held in place with a 4mm Allen bolt). (**Figure 2.1**).

3. Remove the 2 fixings shown in (**Figure 2.2**) to allow for the bride to be attached (**Figure 2.4**) once the shaft bolt is in position.

As shown below (**Figure 2.3**), insert the shaft bolt into the safety brake ensuring it is fully inserted. Put the bride on (**Figure 2.4**), tighten the fixings for the safety brake and bride, then tighten the Allen bolt with a 4mm Allen key. On the opposite plate, fix the motor bracket plate using the provided fixings ensuring the override lines up with the pre-drilled hole.

Figure 2.1



4mm Allen bolt

Figure 2.2



Remove these fixings

Figure 2.3 – Allen bolt



Figure 2.4 – tighten Allen bolt & fixings ensuring that the bride is upright so the open slot is facing the top of the box

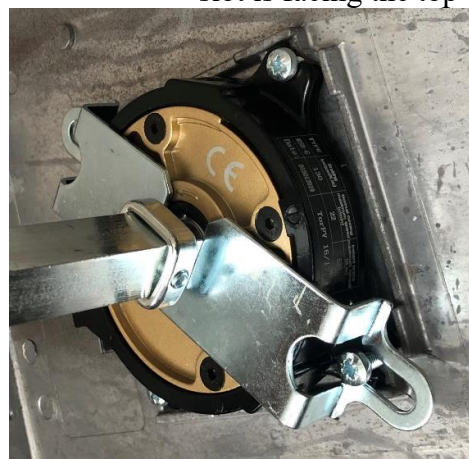

## Step 3 – Preparing The Guide Rails

1. Ensure that the prongs on the inside of the guide channels are facing inwards as shown in the **(Figure 3.1)** below and cut down the guide around 30mm and bend out to the internal to create a leading edge for the curtain (**PLEASE NOTE THIS STEP IS NOT APPLICABLE FOR THE MINI ROLL DOOR**). To ensure your door is fitted level you may have to cut the guide **(Figure 3.2)**. Slide the guide onto the end plate peg and check that the back of the box lines up with the back of the guide **(Figure 3.3)**. Mark each guide – left or right. Remove guides from pegs.
2. Determine method of fitting guides, face fix **(Figure 3.6 & 3.7)** (onto back of the brickwork) or reveal fix **(Figure 3.5 & 3.8)** (between the brickwork) or external **(Figure 3.6 & 3.8)** (onto external face of brick). Drill 7mm fixing holes and enlarge inside holes to 13mm to accommodate plastic buttons **(Figure 3.9)**. Ensure there is a minimum of four good fixings per guide.
3. File the inside of the guide channels – (at the top), to create a chamfered lead in for the curtain.

Figure 3.1



Figure 3.2



Figure 3.3



Figure 3.4



Figure 3.5

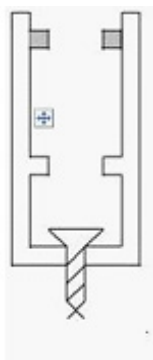

Figure 3.6

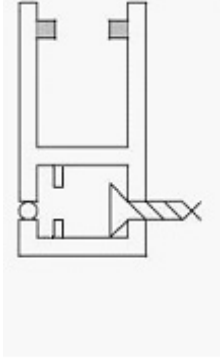

Figure 3.7



Figure 3.8



Figure 3.9



## Step 4 – Fixing The Guide Rails And Box Assembly

1. The guides are offset slightly to ensure correct alignment with the box. Slot the guides onto the end plate pegs (**Figure 4.1**). Ensure the box and guides are located where they are to be fitted. It is vital to level the box assembly and to make sure the guides are square to allow the door to run.
2. Fix the guides to the walls making sure they are not distorted in anyway, pack the brickwork out where necessary. Ensure the fixings used are suitable for the wall properties.
3. Drill suitable holes in the end plates to get secure fixings. This can be through the back of the end plate (**Figure 4.3**) or through the side (**Figure 4.4**). Secure to the walls making sure the box assembly is vertical and follows the line of the guides.
4. Drill and screw the back of the box at regular points along the width of the door to ensure clearance for when the curtain is installed (**Figure 4.4**). This is best done as close to the bottom edge as possible. Make sure all screw heads are flush and not proud as this may damage the surface of the curtain later. Velcro will also be provided as an additional buffer.

**IT IS IMPORTANT TO ENSURE THAT THE CURTAIN IS CLEAR OF THE BACK BOX AND FIXINGS WHEN RUNNING.**

Figure 4.1



Figure 4.2

Figure 4.3

Figure 4.4



## Step 5 – Fitting The Remote Control Unit

The control unit for your door will be packed separately, please follow the instructions, these will be found in the box containing the control unit.

## Step 6 – Installing The Curtain

The curtain will be attached to the barrel by “auto-locks”. Before you install the curtain, you **must ensure that the motor has reached the close limit.**

1. Power up the receiver unit, press the down arrow on the front of the receiver. The barrel will rotate in the close direction. **NOTE:** If the barrel rotation is incorrect, please swap motor direction connections (black and brown from motor). If somfy motor, please ensure bottom limit is pushed in position.
2. To ensure the curtain does not get damaged during fitting, the collars on the barrel must be covered with either cardboard or bubble wrap. This can be removed once the curtain is in position.
3. Tip; before sliding curtain into guides, keeping them in pairs, space auto- lock rings evenly. Carefully remove packaging from curtain. If internal or reveal fit, then the side with the 2 ribbed lines on will show to the outside (like in **Figure 4.4**). If external fit then the 2 ribbed lines will be on the internal face (convex side).
4. Lift the curtain roll and feed the bottom rail over the barrel section into the guide rails. Feed the door into the guide rails approximately halfway and unroll the remaining curtain so the curtain is hanging over the barrel equally.
5. Slide the auto-locks onto the top lathe of the door (**Figure 6.1**).

**NOTE:** There should be 2 rings for every 1 auto-lock.

Figure 6.1



Once you are happy that the rings are spaced evenly, connect the curtain to the barrel using location pegs, ensuring you use the same hole series for every ring (auto locks go between 2 rings).

Carefully slide the curtain to the closed position and attach the autolocks as shown in **Figure 6.2 and 6.3**. **NOTE:** In some cases, it may be necessary to rotate the barrel to enable fitting of the auto-locks. Do this with the manual over-ride, at this stage do not run the motor.

**FIGURE 6.2 – AUTOLOCKING RING**

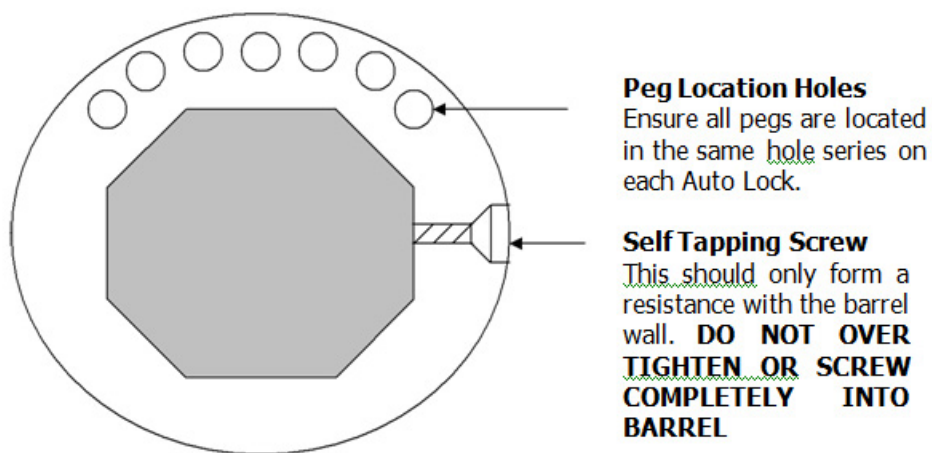

**FIGURE 6.3 – AUTOLOCKING UNIT**

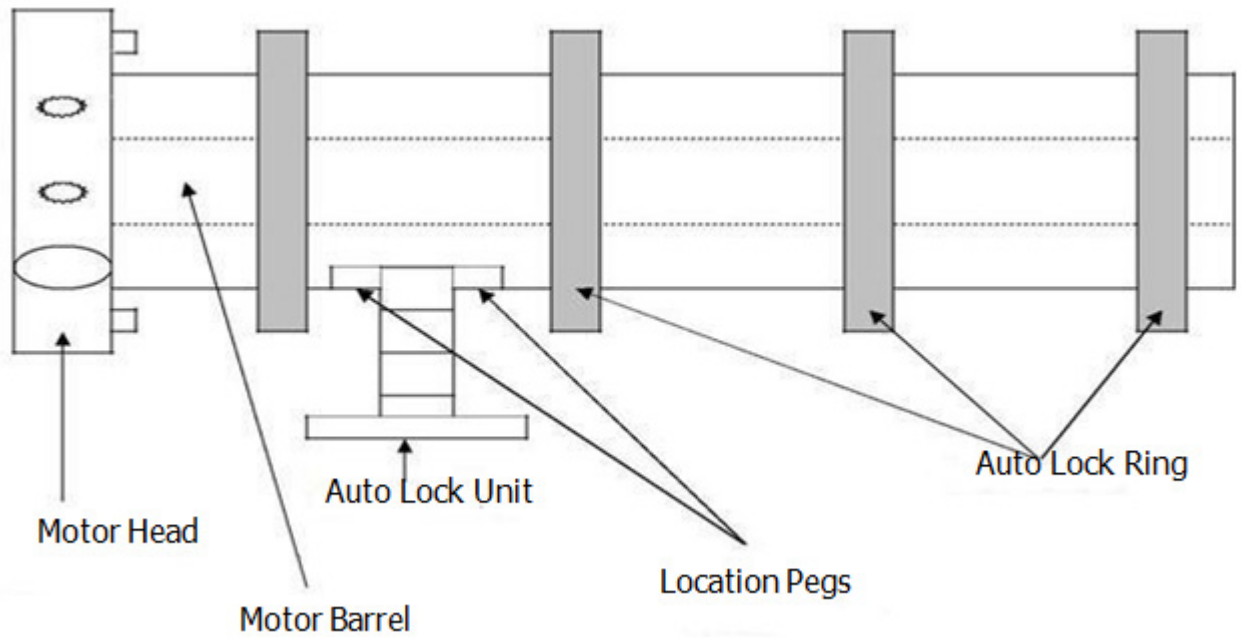

Once the collars are connected and fixed in position, velcro the metal strip along the top of the auto lock which connects to the slat and the rings. (Figure 6.4 & 6.5)

Figure 6.4



Figure 6.5



## Step 7 – Setting The Motor Limits

The following procedure is to be followed when setting the limits of the motor. This can only be done once the following have been completed:

- Door on down limit
- Curtain attached
- Auto-lock rings secured with self-tapper

### Motor Type – Eco Motor

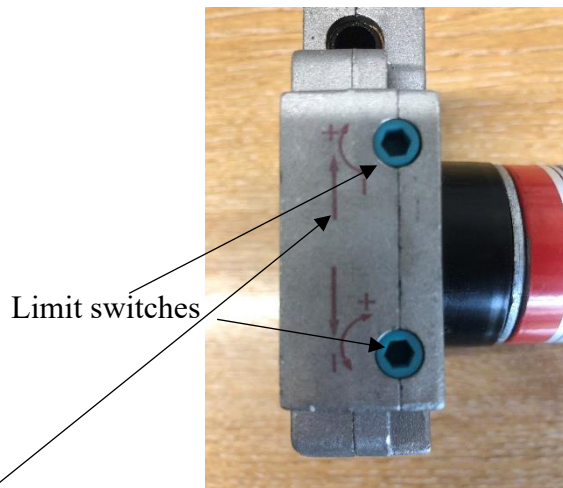

Arrow Direction relates to barrel rotation direction i.e this one is the “UP” limit and the other one is the down limit. Make sure motor cable is also fixed back securely using the P-Clip provided.



Notice that the motor will perform a greater number of revolutions if the screw-limits are turned towards the +, whilst the number of revolutions are decreased when the screws are turned in the – direction.

As the door is already closed, the **Closing Limit** will be the first to be set.

1. Using the buttons on the front of the receiver push the open (top) button. Let the barrel rotate a couple of times and push the stop (central) button. Push the close (bottom) button to see how far the door closes **Note: be ready to push the stop incase the door closes too far.**
2. Check pictures above to determine which screw you need to turn to adjust the closing limit. Using the plastic limit adjuster, turn the limit screw the correct way. Only turn the screw one turn each time. To test the door, repeat step 1.
3. For the door to be in the correct closing position the lathes need to be stacked on top of each other and the auto-locks tight **Note: be carefully not to set the limit down to far as this can snap the auto-locks**
4. Once this is done you can test the closing limit is set correctly by opening the door a foot off the ground and bring it back down.

### **Opening Limit**

1. Using the buttons on the front of the receiver push the open (top) button.

**Note: be ready to push the stop as the door may open past the guides.**

If this happens, bring the door down 2 foot from the opening and turn correct limit screw towards – 2 full rotations. Test the door, always being ready to push the stop button. Repeat until opening limit is found.

**ALWAYS LEAVE THE BOTTOM SLAT IN THE GUIDES WHEN THE “UP” LIMIT IS SET. IF THE “UP” LIMIT IS SET TOO HIGH, THE DOOR WILL NOT RUN.**

**Note:** if the safety edge upgrade has been ordered please refer to steps in instructions found with the control unit.

**NOTE:** The motor unit has an in-built thermal trip that will activate once the motor unit reaches a predetermined temperature. Repetitive usage during the fine adjustment process can cause the motor to cut out. Please wait approximately fifteen minutes for the unit to return to normal operating mode.

## Somfy Motor

Left Hand



Right Hand

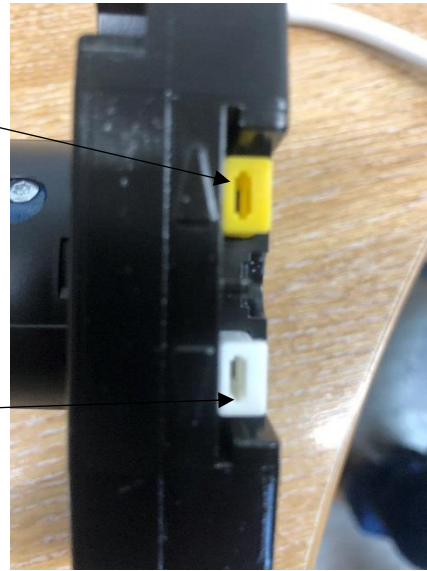

As the door is already closed, the **Closing Limit** will be the first to be set.

Using the control box buttons send to the fully closed position and push in the corresponding button to set the bottom limit. **Note: you can use the manual winder to fine tune the limit if necessary. Note: be carefully not to set the limit down to far as this can snap the auto-locks**

Once this is done you can test the closing limit is set correctly by opening the door a foot off the ground and bring it back down.

### Opening Limit

1. Using the buttons on the front of the receiver push the open button. When in the desired location push the corresponding button to set the up limit. **Note: you can use the manual winder to fine tune the limit if necessary.**

**Note: be ready to push the stop as the door may open past the guides. If this happened use the manual winder to rewind back into the guides.**

**NOTE:** The motor unit has an in-built thermal trip that will activate once the motor unit reaches a predetermined temperature. Repetitive usage during the fine adjustment process can cause the motor to cut out. Please wait approximately fifteen minutes for the unit to return to normal operating mode.

## Step 8 – Fitting The Front Box/enclosure (optional, see step 9 if not required)

1. Unattach the manual override and clip the internal cover into the back box top retaining lip at approximately 10 degrees.

**Note:** Easiest way to achieve this is to start at one end and work your way along

2. Once the cover is located over its entire length place the cover up against the end plates.
3. Drill and fix in place with self-tapping screws or pop-rivets.

✂ Cut down the manual override to the correct size if required and re-insert through the predrilled hole in box lid and fix into position with self-tapping screws.

## Step 9 – Installing The Emergency Override

The end plate will already have a section removed according to the desired motor position and associated exit point for the over-ride bar.

### STANDARD INTERNAL OVERRIDE

1. Align the manual override bar and eyelet with the hole in the motor (**Figure 9.1**) and attach screw using a positive or flathead screwdriver which will be located in the top of the eyelet. (See **Figure 9.2**). If you have a cover then refer to FULL BOX INTERNAL OVERRIDE below.

**Figure 9.1**



**Figure 9.2**

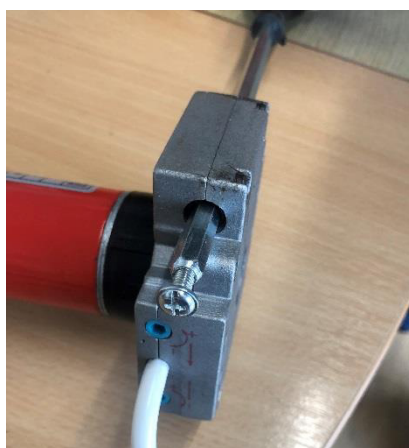

## **EXTERNAL FIT WITH AN EXTERNAL OVERRIDE**

If the door is fitted externally the override will come straight down through the bottom of the end plate. There will be a lock which will be provided that needs to be attached to the front cover, this is to keep the override secure. To install, mark on the cover in line with the motor head where the centre of the hole will be. Use a 25mm hole saw to drill the hole, locate the locking plate into the hole and secure with 2 fixings (rivets or something similar). In case of power failure, simply remove lock cylinder and insert 7mm hex handle straight up into motor.